



HARD FOLDING TONNEAU COVER INSTALLATION GUIDE

364161 MAY/2008	GUIDE FOR FOLD-A-COVER®: FD3711, FD3712	TRUCK MODEL(S): 1997-2007 FORD F-250 SUPER DUTY 1997-2007 FORD F-350 SUPER DUTY
---------------------------	--	--

NOTES TO INSTALLER:

- Install Parts as shown in illustrations.
- Temperature should be no lower than 70° F when installing.
- Be sure the truck is setting on a level surface.
- Apply lock tight to each fastener during installation.
- **Some trimming of bed liner may be required for proper fit and function.**
- Make sure the end user receives the warranty registration envelope, keys, and the operation instructions.



* Truck model shown in images may or may not represent the truck referred to in this installation guide.

NOTES TO CUSTOMER:

- For proper use and maintenance, refer to the operation and care label located on the underside of the rearmost panel on cover (driver's side).



Fold-a-Cover® is a division of Steffens Enterprises, Inc.
4045 Karona Ct. Caledonia, MI 49316
phone: (616) 656.6886 fax: (616) 656.3771

HARD FOLDING TONNEAU COVER INSTALLATION GUIDE

RECOMMENDED TOOLS:

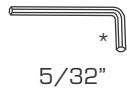
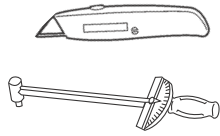

5/32"

*Ball end allen wrench recommended

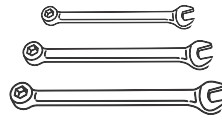
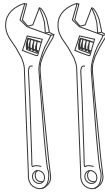

5/16"
3/8"
7/16"



7/16"



PARTS LIST:

A	3505	1/4-20 x 1 3/4 SHCS
B	3682-99L	LH Wind Seal
C	3682-99R	RH Wind Seal
D	3447	Support Washer
E	3324A	Stake Pocket Nut
F	3410	Hinge Bracket
G	3411	Hinge Bracket Shim
H	3509	#10-32 x 1/2 SHCS
I	3506	1/4-20 x 2 1/4 HHCS
J	3508	1/4-20 Jam Nut
K	3407A	C-Clamp
L	3510	1/4" Lock Washer
M	3504	1/4-20 x 1 HHCS
N	3409SA	C-Clamp Shim w/ Tape
O	3658	Flat Washer, 1/4 USS
P	3647	Front Striker Clamp
Q	3651	Striker Bolt
R	3656	T-Nut 5/16-18
S	3653 (6'9") 3661 (8'0")	Center Latch Clamp
T	3662	Inner Clamp Bracket
U	3652	Rear Striker Clamp
V	3650	Front Inner Clamp Bracket
W	3691B	Striker Clamp Shim
X	2095	Adhesion Promoter
Y	3689-70	Blade Seal

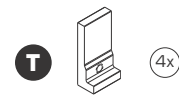
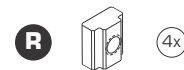
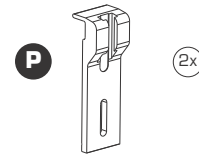
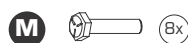
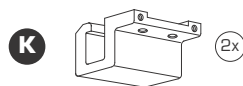
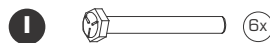
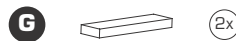
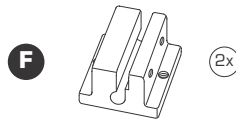
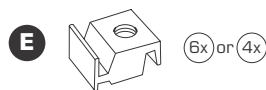
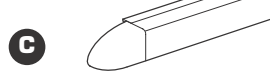
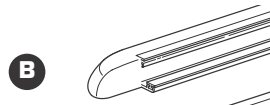
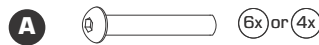

HARD FOLDING TONNEAU COVER INSTALLATION GUIDE

TEMPLATE: STAKE POCKET TEMPLATES FOR 6' 9" BED

TEMPLATE:
USE THIS TEMPLATE TO MARK THE EXACT LOCATIONS
ON THE F-250/350 6' 9" BOX

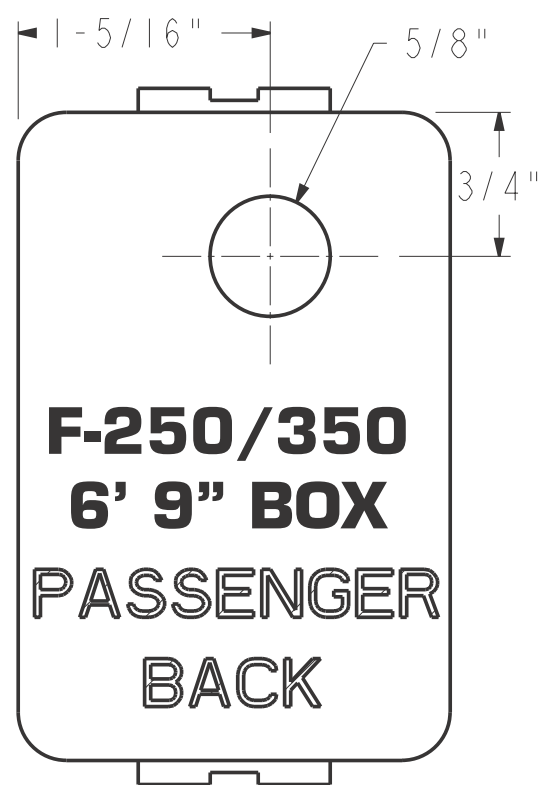
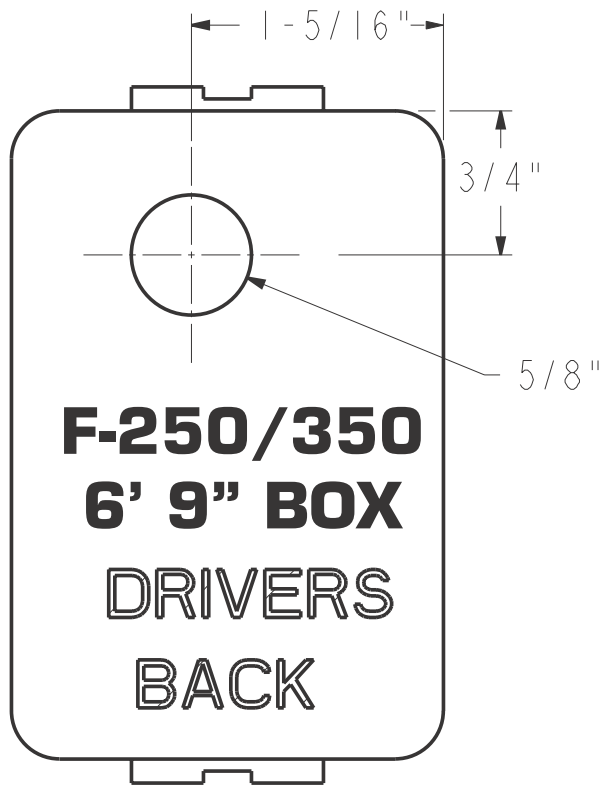
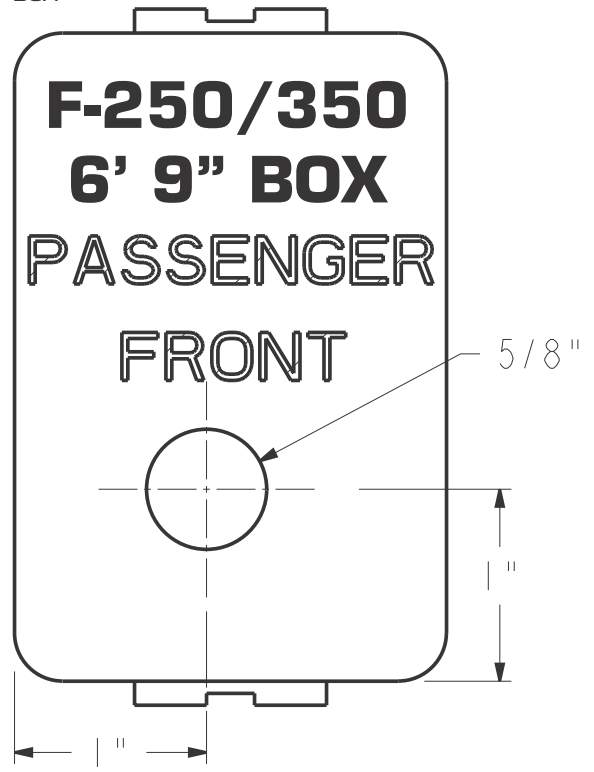
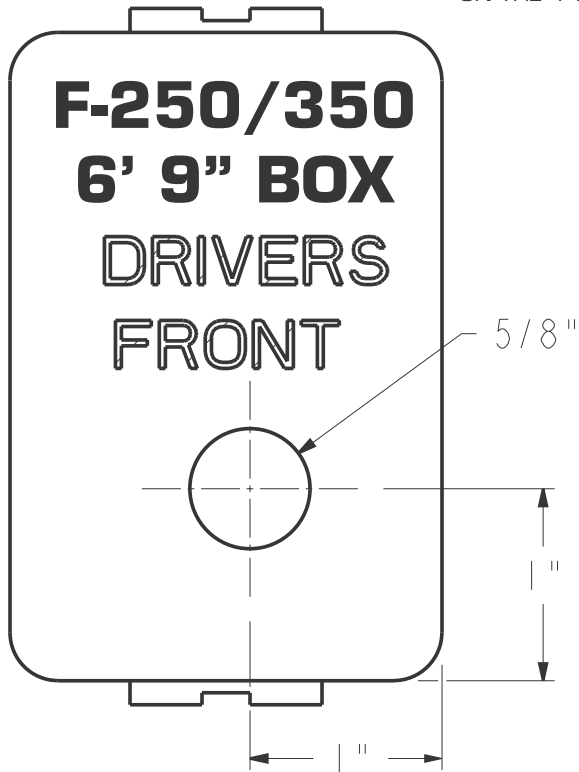

HARD FOLDING TONNEAU COVER INSTALLATION GUIDE

TEMPLATE:

STAKE POCKET TEMPLATES FOR 8' BED

TEMPLATE:
USE THIS TEMPLATE TO MARK THE EXACT LOCATIONS
ON THE F-250/350 8' BOX

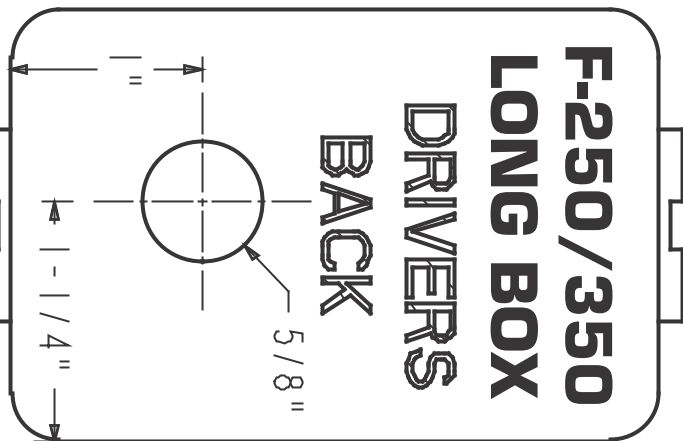
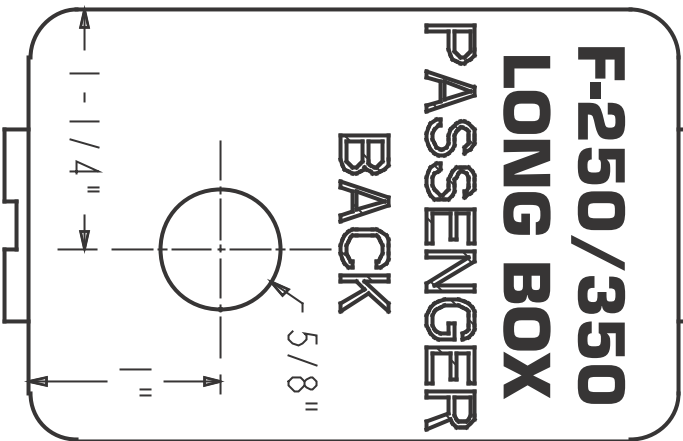
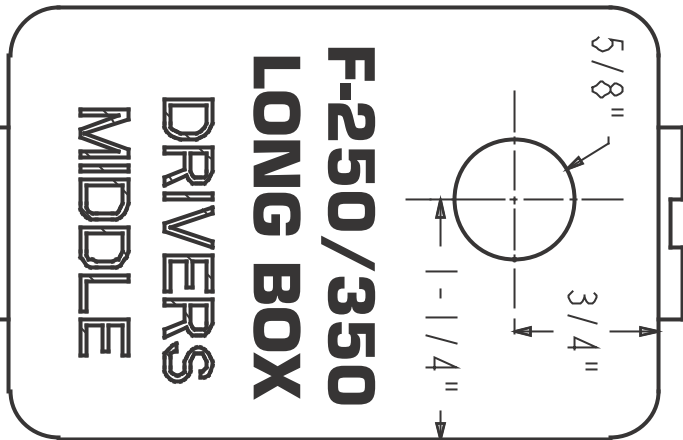
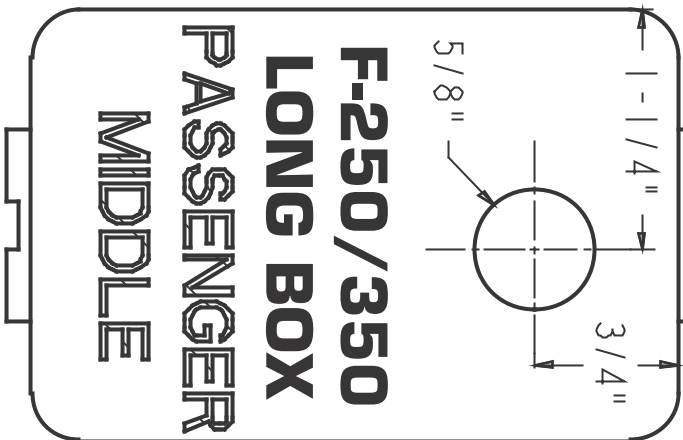
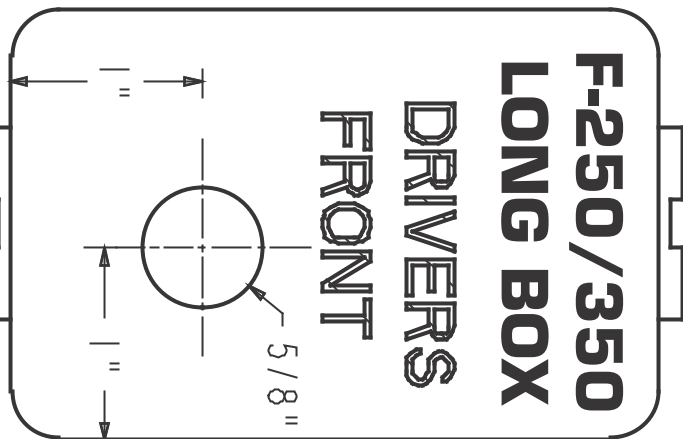
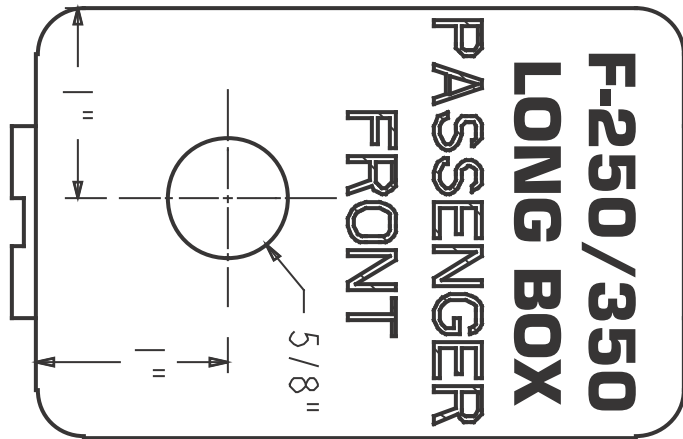

STEP ONE: STRIKER CLAMP BRACKET INSTALLATION

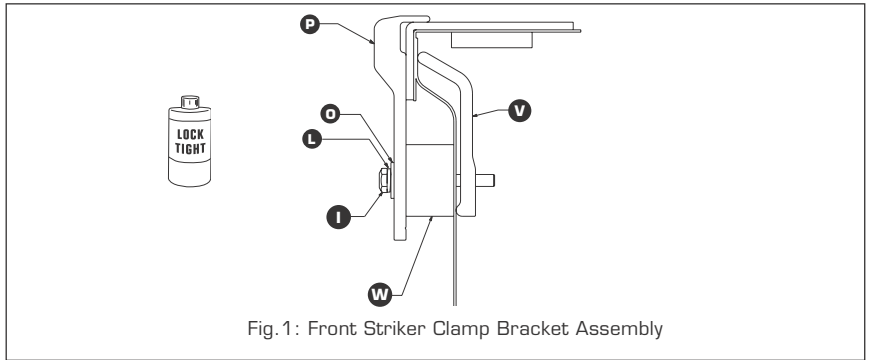

Fig. 1: Front Striker Clamp Bracket Assembly

INSTALL FRONT STRIKER CLAMP BRACKETS:
Insert the front inner clamp bracket (V) (long leg up for the front stake pocket) into the stake pocket hole as pictured allowing the upper leg of the clamp to rest on the inner ledge inside of the stake pocket and hold the clamp in place.

Insert the bolt (I) and washers (L & D) through the slot in the striker clamp bracket (P) through the square striker clamp shim (W) see illustration.

Hold the assembly in place allowing the threaded end of the bolt to pass through the oblong hole in the inner wall of the box and thread the bolt into the inner clamp bracket. Tighten the assembly finger tight.

Note: Do not attempt to install striker clamp brackets or center latch clamps over bed liners. Some trimming of bed liner may be required for proper fit and function.



Position the finger tight clamp assembly in the center of the stake pocket as pictured. Make sure the striker clamp shim is in place and aligned with the bottom of the clamp.

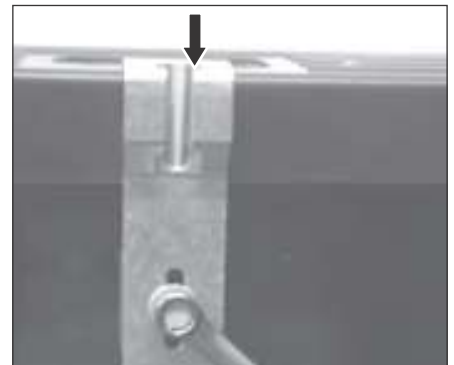

Apply downward pressure to the clamp assembly while tightening bolts to 70 in. lbs. or (7.9 N. m.) Repeat these steps for both passenger side and drivers side front clamps.

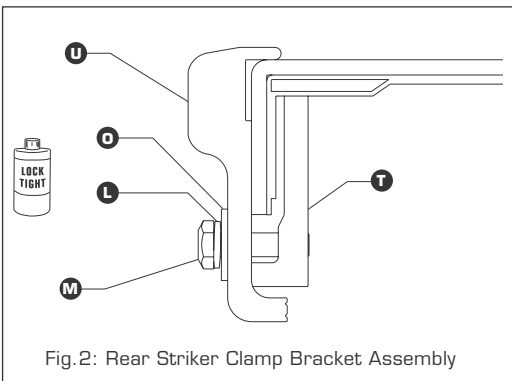
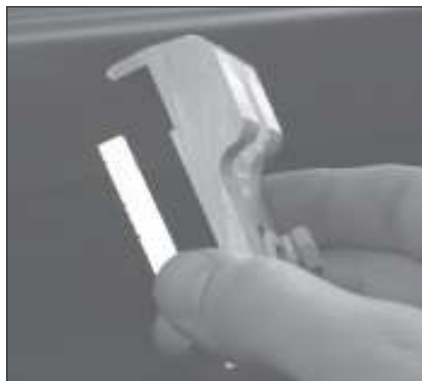

Fig. 2: Rear Striker Clamp Bracket Assembly

PLACE THE REAR STRIKER CLAMP BRACKETS:



Position the finger tight striker clamp bracket assembly as far to the rear as possible as shown above. Leave the assembly **finger tight** for final position adjustment in step 7.



Note: Do not fully tighten bolts at this time. Leave the assembly finger tight until step seven.

HARD FOLDING TONNEAU COVER INSTALLATION GUIDE

STEP TWO: WIND SEAL (SIDE RAIL) APPLICATION

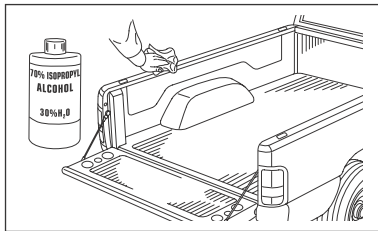

WIPE DOWN BOTH SIDE RAILS
Using a clean cloth and 70% Isopropyl Alcohol, wipe down both side rails to ensure a clean surface for installation.



REMOVE PROTECTIVE BACKER FROM WIND SEAL RAILS:
Remove the protective film from the passenger and drivers side wind seal rails (B & C).

Note: The foam tape is for surface protection and sealing on this application and is not adhesive.

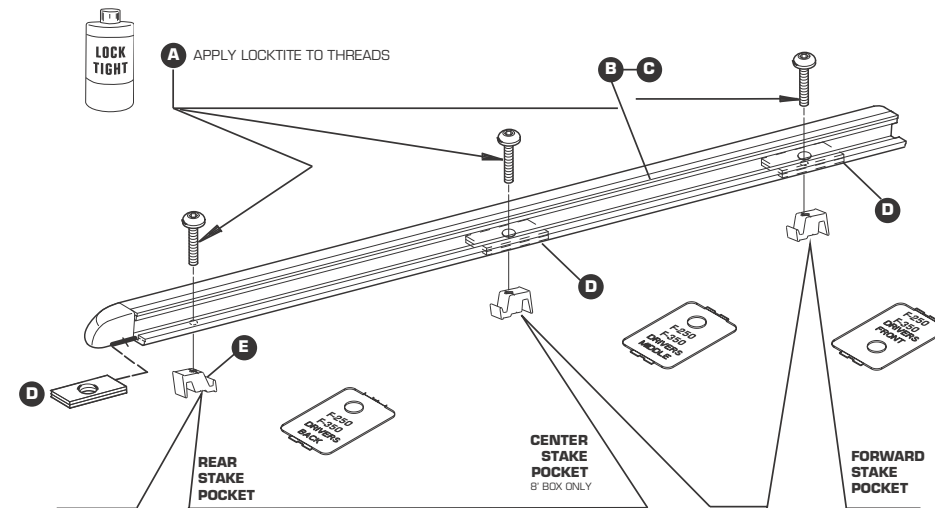

Insert the support washers (D) into the wind seal rails as pictured above.



Insert the 1 3/4" socket head bolts (A) through the support washer and through the slotted hole in the wind seal rail. Note: Using your thumb hold the upper and lower rubber seals out of the way as you insert the bolt through the spacer and wind seal rail.

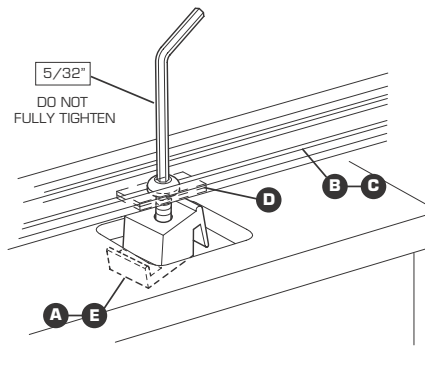
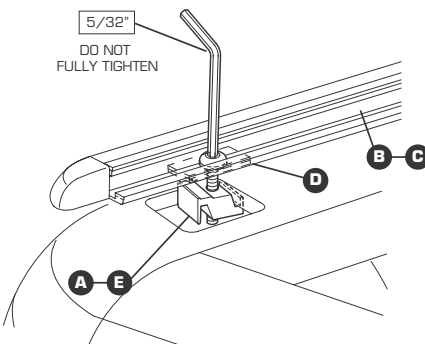

Note: 6'9" boxes have 2 stake pockets per side. 8' boxes have 3 stake pockets per side.



Thread the stake pocket nuts (E) onto the bolts; thread the nut approximately five turns. Note: The shallow groove in the stake pocket nut should face up toward the bottom of the wind seal rail as shown in the illustrations.



SECURE WIND SEAL RAIL TO VEHICLE
Align the completed wind seal rail assembly on the top of the box (see diagram above and picture to left) allowing the stake pocket bolts and nuts to drop into their respective stake pockets. Starting at the forward stake pocket on the driver's side of the vehicle make sure the stake pocket nut engages the stake pocket lip and hold a slight upward pressure on the rail.

Using a 5/32" allen wrench tighten the socket head bolt until the rail draws down and makes slight contact with the top of the box; only finger tight. Repeat these steps until all of the stake pocket nuts are finger tight on both the drivers and passenger side wind seal rails.

HARD FOLDING TONNEAU COVER INSTALLATION GUIDE

STEP THREE: INITIAL COVER PLACEMENT

NOTICE: Assistance may be required to perform this step.

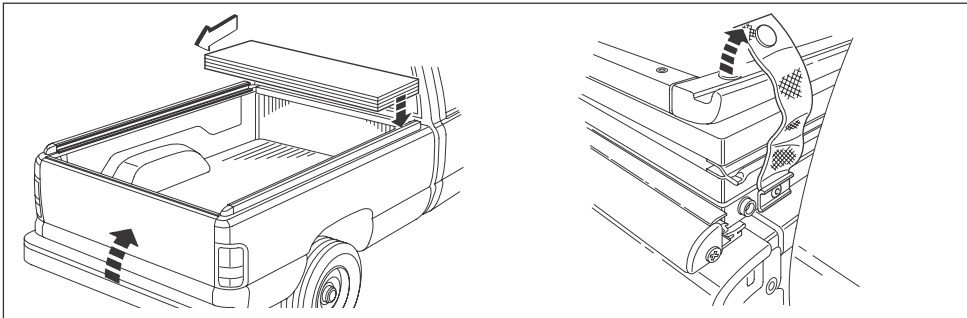

PLACE COVER BETWEEN WIND SEAL RAILS:
Carefully remove the folded cover from the shipping box and remove packing materials from the corners of the cover.
Note: Retain two of the foam corner blocks for Step Nine.

Place the cover between the wind seal rails at the front of the truck bed and release the three snap restraints as shown in the diagram and pictures above.



Pictured: Detaching snap restraint from cover.

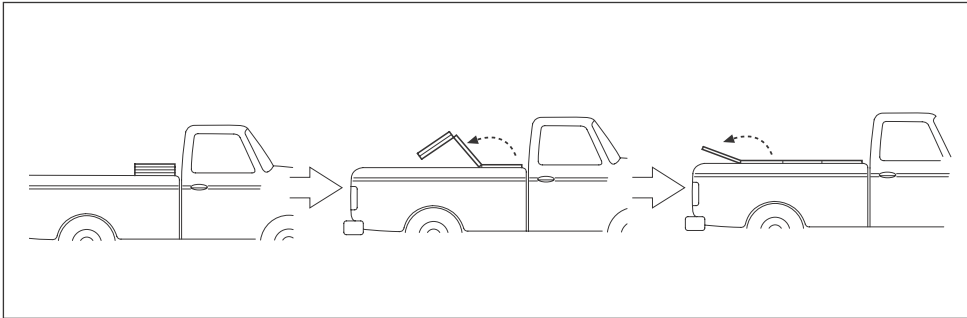

CAREFULLY UNFOLD COVER:
Unfold the cover between the installed wind seal rails on the truck bed.

It may be necessary to adjust the wind seal rails for the cover to fold out flat and sit between the wind seal rails.



Pictured: Unfolding cover between wind seal rails.

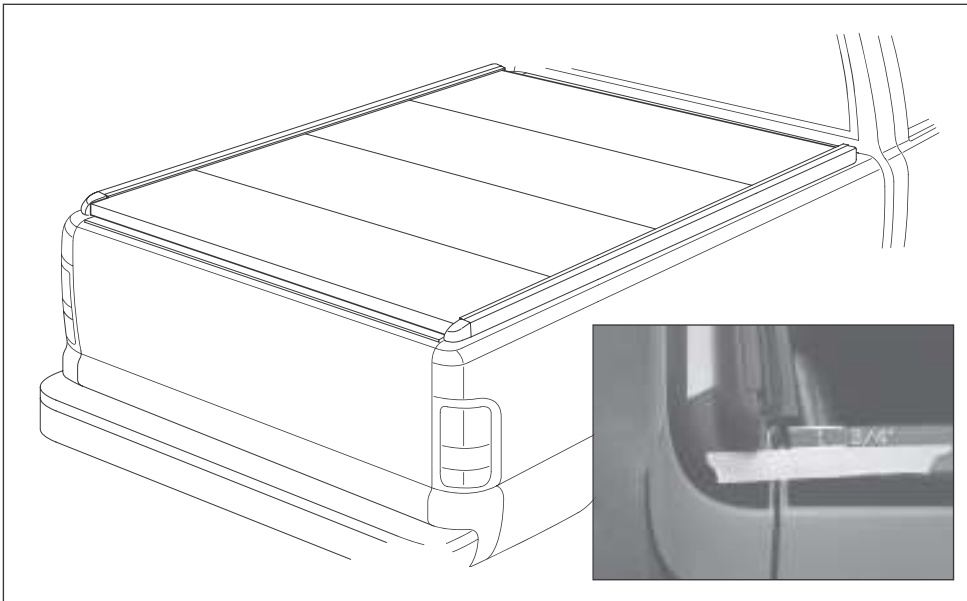

ADJUST PLACEMENT OF COVER:
Adjust the front to rear placement of the cover so that the rear panel of the cover is 3/4" onto the tailgate. See inset picture above.

Center the cover **evenly** and **squarely** from side to side on the truck bed.



ALIGN LH & RH WIND SEAL RAILS TO THE COVER:
Make sure the upper rubber seal of the wind seal rails are evenly spaced 1/32" to 1/16" from the top edge of the cover for the entire length of the cover, front to back on both sides. Also align the rear of the wind seal rails with the rear panel of the cover on both sides.

HARD FOLDING TONNEAU COVER INSTALLATION GUIDE

STEP FOUR: SECURE COVER TO TRUCK BED

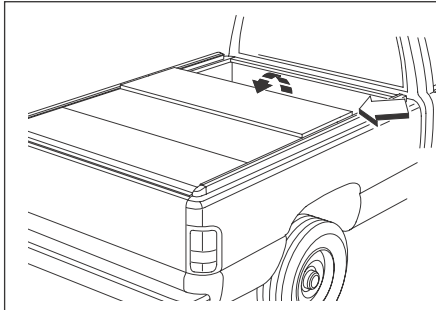

FOLD BACK FRONT PANEL:

Carefully fold back the front panel.
Note: Make sure cover does not move from its centered position on the truck bed.

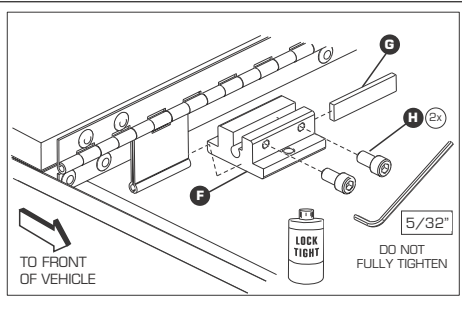

ASSEMBLE HINGE BRACKET:

Assemble drivers side and passengers side hinge brackets (F, G & H) finger tight as shown in the diagram and picture above.



Pictured: Attaching Hinge Bracket to Cover.

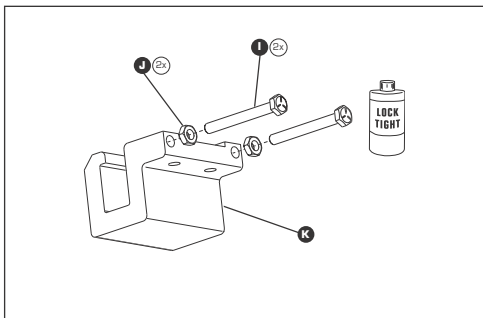

PREPARE C-CLAMP ASSEMBLY:

Assemble drivers side and passenger side C-Clamp units (I, J, & K). Thread the jam nut (J) all the way onto bolt (I) and thread them into C-Clamp (K) as shown in diagram above.

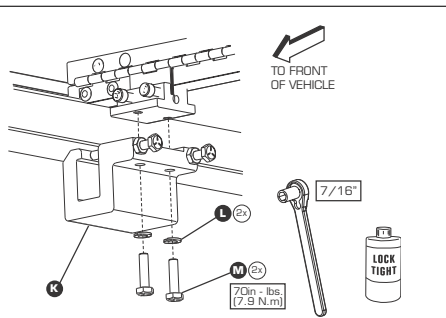

ATTACH C-CLAMP TO HINGE BRACKET:

Using bolts (M) attach the C-Clamp units to the hinge brackets and tighten the bolts to 70 in. lbs. (7.9 N. m.).



Pictured: Attaching C-Clamp to truck bed and Hinge Clamp.

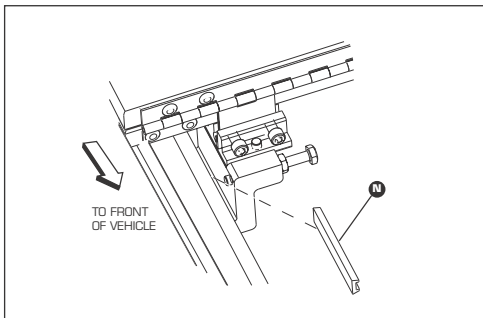

INSERT C-CLAMP SHIM:

Insert the C-Clamp shims (N) as shown in the diagrams above and thread the C-Clamp bolts in finger tight until the bolt contacts the center groove in the shim.

Note: Make sure both of the C-Clamp bolts contact the shim and that the C-Clamp assembly and shim are parallel with the top of the truck bed. Avoid any downward pressure on the C-Clamp assemblies as they are tightened.

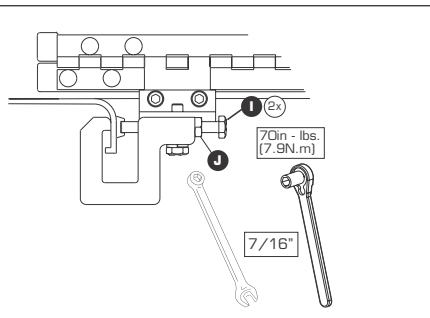

TIGHTEN BOLTS AND JAM NUTS:

Check the shim alignment and tighten the bolts to 70 in. lbs. (7.9 N. m) and then tighten the jam nuts.



Pictured: Securing C-Clamp jam nut with 7/16" wrench.

SECURE HINGE BRACKET BOLTS:

Tighten hinge bracket set bolts to 25 in. lbs. (2.8 N. m.)
Note: Make sure hinge bracket shim (G) is seated to the bottom of the receiver groove in the hinge bracket.

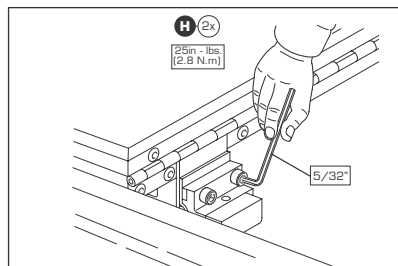

HARD FOLDING TONNEAU COVER INSTALLATION GUIDE

STEP FIVE: ATTACH CENTER LATCH CLAMPS



With the tailgate open and the rear cover panel closed, locate the center latch mechanism on the bottom of the number three panel.

Using masking tape, mark the center of the latch mechanism on truck bed rail as shown in the picture above. Repeat for both driver and passenger sides.



Open the cover to its fully open position and install the center latch clamps (S, T, L, M & O) as shown in the picture above.



Using the 7/16" wrench, apply downward pressure to the clamp assembly while tightening center latch clamps to 70 in. lbs. (7.9 N. m.).



With the center latch bracket in place and the tailgate in the open position, close the rear panel of the cover. Closing the rear panel engages the center latch mechanism. The center latch cam should operate freely when the rear panel is closed and the cam should rotate under the center latch bracket as picture above.

IMPORTANT NOTE:

ALWAYS FULLY OPEN THE REAR PANEL FIRST AND CLOSE THE REAR PANEL LAST.

To insure proper operation of the center latch mechanism always open and fold the rear panel of the cover to its fully open position before starting any folding motion of the second or third panels, continue the opening sequence by folding the second and third panel to the fully open position and secure the docking straps. To close the cover, reverse these steps in the same order, making sure to close the rear panel last.

STEP SIX: INSERT STRIKER BOLTS



INSERT AND SECURE STRIKER BOLTS:
Pre-assemble the striker bolt with 2 washers and thread it into the T-nut.



With the front and rear panels still in their fully open positions, install the striker bolts, T-nuts and washers (Q, R & O).

Slide the T-nut assembly into the T-slot in the striker clamp bracket as shown in the picture above.



Tighten the striker bolt finger tight and repeat this step for all four of the striker clamp brackets.

HARD FOLDING TONNEAU COVER INSTALLATION GUIDE

STEP SEVEN: ALIGN & ADJUST ROTARY LATCHES



OPEN POSITION



CORRECT

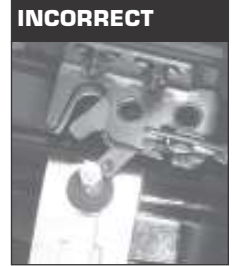

INCORRECT

Open the tailgate of the truck. Make sure the rotary latches are in their open position on both panels.

Gently lower either the front or the rear panel toward its closed position making careful note of the alignment of the striker bolts on the truck and the U-shaped striker bolt receiver in the rotary latch on the cover.

When the rear striker clamp bracket assembly is correctly positioned as shown, tighten the bolts to 70 in. lbs. or (7.9 N. m.) Repeat for both passenger and drivers side.



If the striker bolt is not centered adjust it as follows. Loosen the 3/8" nuts on the latch assembly to slide the latch fore or aft until it is centered over the striker bolt on the truck.



Note: (If the rotary latch can not be properly adjusted check the position of the striker clamp assemblies. Additional adjustment is available by loosening and repositioning the striker clamp bracket assembly)



Repeat until all four latches are centered over their respective striker bolts.



Close the tailgate of the truck and return the cover to its fully closed position on both the front and rear panels. Re-check the spacing and alignment of the wind seal rails with the cover.



Open the front and rear panel to expose the wind seal rail bolts and using the 5/32" allen wrench tighten the wind seal rails to 70 in. lbs. (7.9 N. m.)



Return the cover to the closed position to make the vertical adjustment of the striker bolts. Use the 5/16" wrench to adjust the striker bolt height as shown in the picture above.



With the front and rear panels in their closed positions the top of the cover should be adjusted flush with the top of wind seal rails. Tighten the four striker bolts to 70 in. lbs. (7.9 N. m.).



To close and latch the front or rear panels simply use a smooth, firm downward pressure on the panel. (Start the downward closing motion approximately 12 inches before the panel reaches its closed position)



Note: Striker bolt setting may require readjustment after blade seals are installed in Step Eleven.

STEP EIGHT: ADJUST LATCH TIMING



Hold the rear panel in an open position at approximately a 45 degree angle with one hand. With your other hand manually close both the driver and passenger side rotary latches.

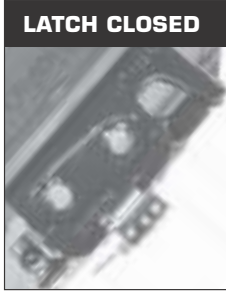

LATCH CLOSED

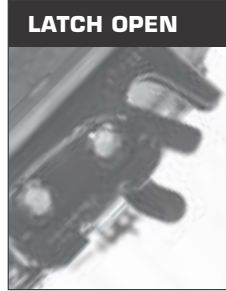

LATCH OPEN

With the cover in this suspended position operate the latch release handle. Both latches should open at the same time about half way through the travel of the latch release handle. If both latches release simultaneously no further adjustment is required, and you may tighten the cable end jam nuts as pictured below.



If any adjustment is required simply adjust the cable length at either latch as shown.

Turning the cable end nut clockwise will make that latch release sooner; turning the cable end nut counter-clockwise will make that latch release later. When adjustments are complete, you may tighten the cable end jam nuts as pictured to the right.



Using two small adjustable wrenches tighten the cable end jam nuts.

Repeat this adjustment sequence for the latches on the front panel.

HARD FOLDING TONNEAU COVER INSTALLATION GUIDE

STEP NINE: ATTACH FRONT & REAR BLADE SEALS

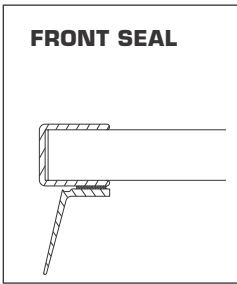
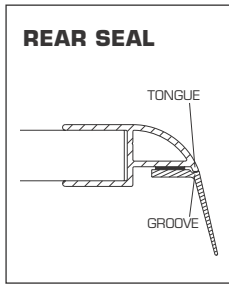

SURFACE TEMP
70°F
OR ABOVE

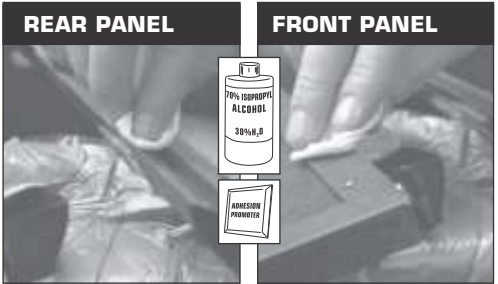

Note: Using 2 foam corner packing blocks support the open front and rear panels of the cover as shown.

Surface temperatures below 70 degrees F will adversely effect the bond strength of the seal adhesive.

With the front and rear panels open and supported on the foam packing blocks; clean the seal surfaces with 70% isopropyl alcohol.

Note: Surface must be free of dust, dirt, oil and moisture. Make sure to clean the seal mating surfaces with either isopropyl or denatured alcohol as these solvents leave no residue that could effect the bond strength.

Apply the adhesion promoter (X) to both panels as shown in fig. 1. Allow the adhesion promoter to dry to the touch before starting the blade seal installation.



ATTACH REAR BLADE SEAL

Expose a small section of the adhesive tape (4"-6") on the blade seal (Y) as shown in fig. 2. Align the seal with the end of the panel making sure the tongue on the panel and the groove in the seal fit together as shown in the line drawing (far left).



Work across the panel exposing small sections of the adhesive and aligning the seal.

Note: Do not stretch the seal as it is being placed on the cover.



ATTACH FRONT BLADE SEAL

When you reach the end of the panel trim the excess seal material flush with the end of the panel with the razor knife. Firmly press the seal in place across its entire length.



Expose a small section of the adhesive tape (4"-6") on the blade seal (Y) and align the seal with the back edge of the channel starting 1/2" from the outside edge of the cover as shown in fig. 5.



Work across the panel exposing small sections of the adhesive and aligning the seal. When you reach the end of the panel trim the excess seal material 1/2" from the outside edge of the cover with the razor knife as shown above.



APPLY PROTECTANT TO UNDERSIDE OF BLADE SEALS USING A CLEAN CLOTH:

With the seals completely installed apply a light coat of Armor All® or a similar silicone protectant to the underside of both the front and rear blade seals using a clean, dry cloth.

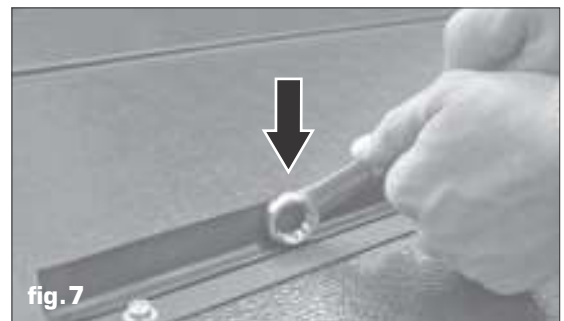

To ensure proper transfer of the adhesive use the box end of a combination wrench or a similar tool to apply concentrated pressure to the blade seal as shown in fig.7. Start at one end of the seal and work the tool across the panel applying firm even pressure. Repeat for both the front and the rear seal.

Note: Closing the cover requires a smooth, firm downward pressure on the panel. Due to the nature of the rubber blade seals, it will initially take extra closing pressure until the memory in the seal material conforms to the seals final shape in the closed position.

HARD FOLDING TONNEAU COVER OPERATIONAL INSTRUCTIONS



To open the cover lift the latch release handle and open the rear panel to the fully open position.



To insure proper operation of the center latch mechanism always open and fold the rear panel of the cover to its fully open position before starting any folding motion of the second or third panels.



Continue the opening sequence by folding the second and third panel to the fully open position.



With the cover in the fully open and stacked position secure all three docking straps. It is important to secure the docking straps at all times when the cover is in the fully open position.



To close the cover, reverse these steps in the same order, making sure to close the rear panel last.

Note: Only operate the vehicle with the cover in the closed and latched position or the fully open position with the docking straps securely fastened. Operation of the vehicle with the cover in partially opened positions can cause severe damage to the cover and possibly the vehicle.